



TS9800 Series Jet Valve Dispensing

The TS9800 Series is the fastest non-contact
Jet Valve dispensing system

The TS9800 Series is a smart jet valve dispensing system that includes a TS9800 Piezo actuated jet valve and TS980 smart controller. The new smart jet valve delivers ultra-fast and high precision dispensing results for a wide range of adhesives and viscosities. The highspeed piezo actuator enables the valve to dispense as fast as 1500 Hz. continuously with up to 2000 Hz maximum burst and produce micro shot as small as 0.5 nL.

TS9800 series jet valve compact size and modular design aids integration into robotic systems. The valve features fully adjustable parameter settings, allowing the operator to change the jetting properties for different fluid types and optimize the process for repeatable dispensing.

Every component of the valve was designed to the highest tolerances and manufactured to the strictest degree of precision insuring world class accuracy and repeatability in drop-to-drop dispensing volume.

TS980 smart controller features an intuitive touchscreen user interface for easy setup and operation. Dispensing parameters can be quickly dial-in on the touchscreen.

The best-in-class smart controllers come standard with an Internet port to allow users to monitor, record data and make precise parameter adjustments from remote locations. This feature enables the units to fit into the Smart factory that requires Industry 4.0. In addition, troubleshooting and training can be done remotely through an Ethernet connection.

KEY FEATURES AND BENEFITS:

- Fast dispense frequency, up to 1500 Hz continuous, with up to 2000 Hz maximum burst for higher throughput
- Micro shot size as small as 0.5 nL for small component applications
- Capable of jetting low to high viscosity fluid
- Localized fluid housing heater for better viscosity stabilization and dispensing (optional)
- Touch screen user-friendly interface for easy setup
- Parameters can be adjusted remotely

TYPICAL APPLICATIONS:

- Edge sealing, end sealing of LCDs and OLEDs
- Die bonding, Frame bonding for camera module assembly
- Jetting silicone phosphor in the LED assembly process
- Jetting under-fill in micro-electronic package applications on PCBA
- Jetting micro dots of UV adhesive in medical device applications

SPECIFICATIONS

Size Valve (inch) W x D x H:	0.63 x 2.7 x 4.9
Size Valve (mm) W x D x H:	16 x 69.3 x 124.8
Size Controller (inch) W x D x H:	5.40 x 7.13 x 4.96
Size Controller (mm) W x D x H:	137 x 181 x 126
Weight Valve:	258 g
Weight Controller:	2110 g
Max Fluid Pressure:	6.9 bar
Nozzle Orifice Diameter Range:	0.05 mm to 0.40mm
Parameter sets Memory	50 sets internally; unlimited ext.
Standard Interface:	DB15, RS-232, Ethernet, USB
Operating Temperature:	10 °C – 50 °C
Power Connection	110/240 VAC; 50/60 Hz
Certification	TUV, KC, PSE, NRTL, CE

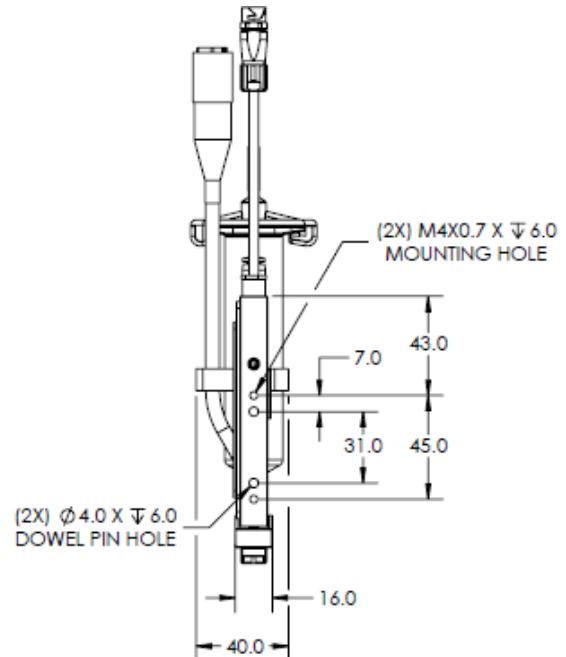
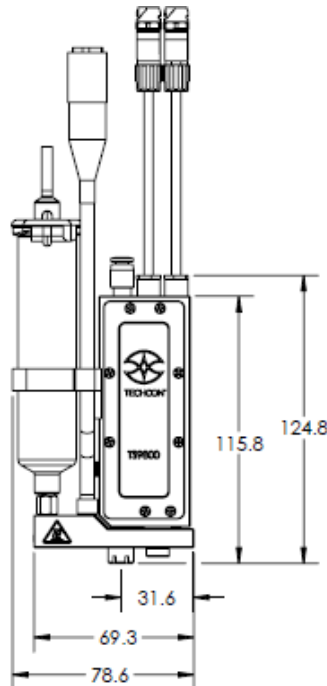
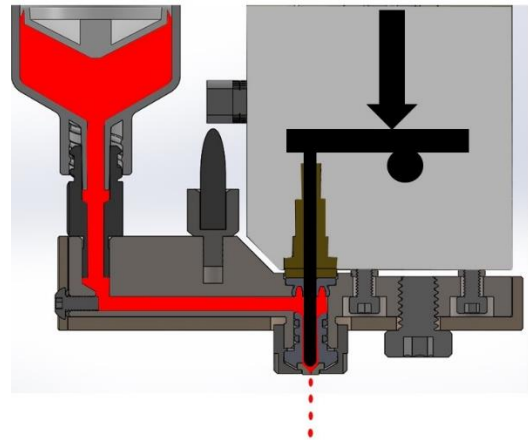

The valve is shipped with the following items:

- 30 CC Syringe Bracket
- 10 CC Syringe adapters
- Luer fluid inlet fitting

Techcon Corporate Headquarters

10800 Valley View Street,
Cypress, California 90630
USA

Tel: 1-714-230-2398

E-mail: oemorders@okinternational.com